

Fire Rated Glass Door



**FIRE
INTEGRITY
UP TO
180min.**

This is the system for flush mounted single or double-leaf swing doors, single and double-Leaf sliding doors without a thermal break. Manufactured from cold rolled mild steel Profiles, with square cut Snap-on glazing beads; the system has a nominal depth of 50mm and 60mm; the profile can also can be welded together to form complex constructions. The system has been comprehensively tested to both the European and North American Standards for fire resistance. The materials are galvanized or stainless steel profiles that best combines the aesthetic requirements and technological innovation inside the system design. Designed, tested and certified for fire EI (Integrity and Insulation) classification up to 120 minutes of fire resistance, and for EW (Integrity & Radiation Control) and E (Integrity) fire classifications.

Features and Benefits

- Fire protection
- Smoke protection
- Burglary-resistance
- Bullet resistance
- Thermal break
- Explosion inhibition
- Minimal face widths
- Without thermal break
- Finger protection
- Great acoustic performance
- Interior & exterior use
- Multiple finishes.
- Suitable for manual or automatic door operator.

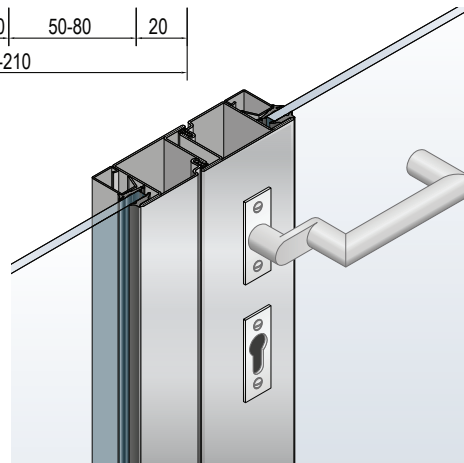
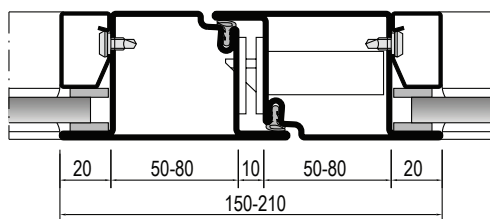
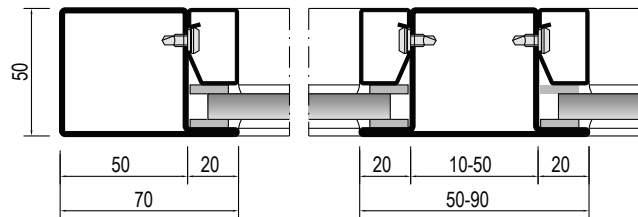
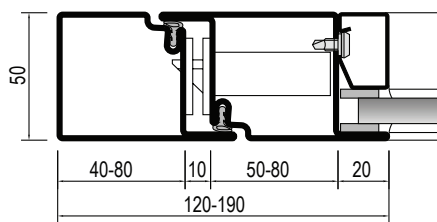

Technical Data

	Description	Result	Standard
Material options	Zinc magnesium (ZM) coated steel		
	Stainless Steel grade 304 and 316 (brush finish grain 220-240)		
	Available profile depth: 50 and 60mm		
Fire resistant options	Fixed partitions	E30 to E120 EW30 to EW120	EN 1364-1
	Single and double doors	E30 to E180 EW30 to EW120	EN 1634-1
	Single and double automatic sliding doors	EW30 to EW120	EN 1634-1
	Single action, rebated, unlatched swing doors (single and double leaf)	EW30 to EW120	EN 1634-1
	Double action, non rebated, unlatched swing doors (single and double leaf)	EW30 to EW60	EN 1634-1
Fire code compliance	European and North American Standards		
	NFPA 101 and NFPA 80		
Tested design variants*	Smoke resistant doors	Sa, S ₂₀₀	EN 1634-3
	Fire resistant doors and screens		
Fittings	Hinges		
	Door closer		
	Door closers complete with in house cycling testing		
	Latch locks, lever handles, Self-closing flush bolts		
	Roller latches (for unlatched doors)		
	Compatible with access control devices		
System properties	Extremely slender visible section widths and depth		
	Can be powder coated or wet paint coated (to be checked with local applicator)		
	Large glass panels available for fire rated systems		
	Large door sizes available for fire rated systems		
	Extremely economical manufacturing without special equipment		
	Robust system, resistant to damage		
	Sound insulation (hinged doors, depth 50 mm)	Up to 42 dB	EN ISO 140-3
	Sound insulation (fixed screens, depth 50 mm)	Up to 46 dB	EN ISO 140-3
Sound insulation (hinged doors, depth 60 mm)	Up to 45 dB	EN ISO 140-3	
Sound insulation (fixed screens, depth 60 mm)	Up to 48 dB	EN ISO 140-3	

*Refer to country-specific approvals